

65" | 75" | 86"

SMARTBoard® T-Pro

Interactief display

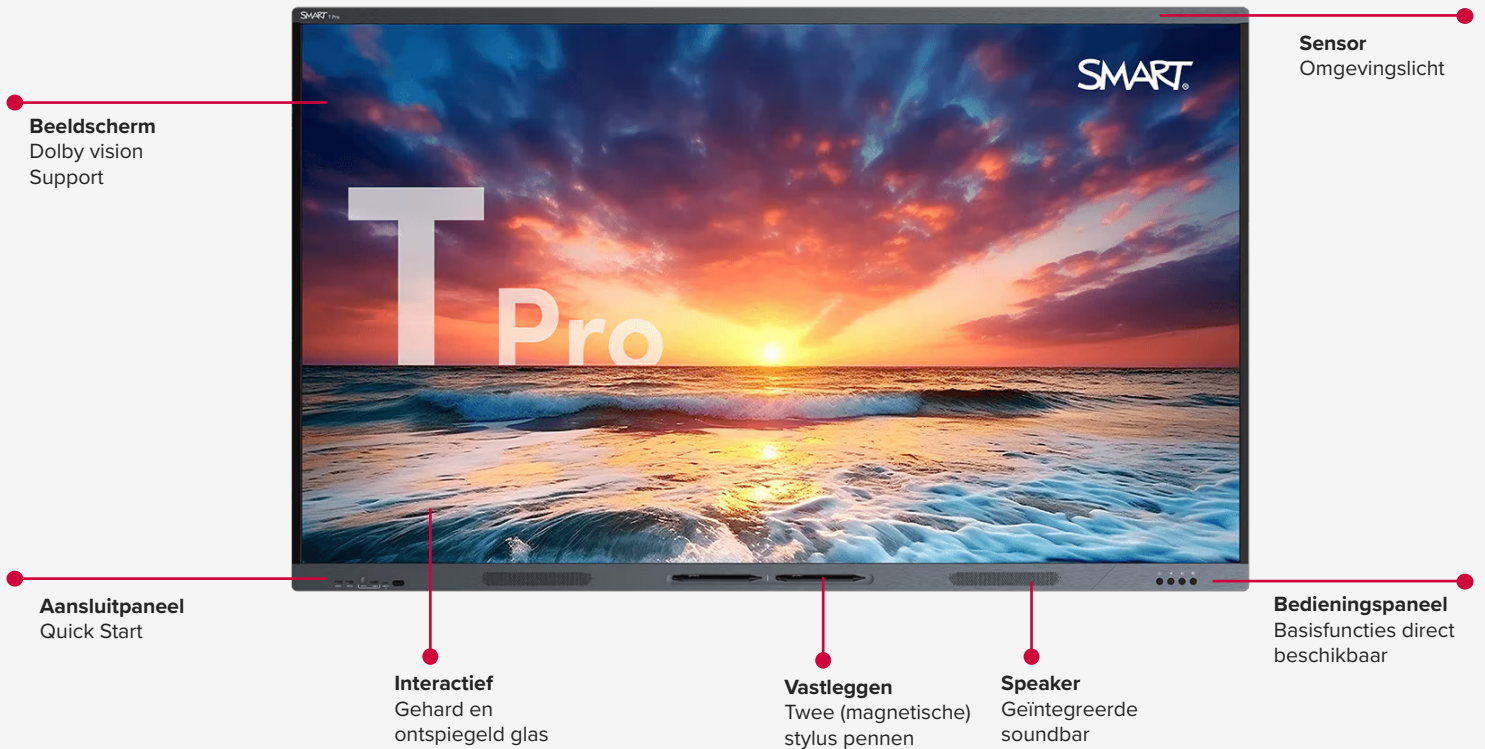

- ✓ Geborstelde luxe metalen afwerking
- ✓ HyPr Touch met geavanceerde IR
- ✓ Full featured USB-C met high power delivery
- ✓ HDMI 2.1 Ultra HD 4K 60Hz
- ✓ 2 x 20W stereo soundbar met subwoofer
- ✓ Hoogwaardige QLED display
- ✓ OPS computer slot
- ✓ Zero bonded glass technologie

Uw SMART Board ophangen

Montage opties



Bekijk alle montage opties op smartboard.nl/shop

VERRIJDBAAR ONDERSTEL	DESIGN WAND/VLOERLIFT
	
<ul style="list-style-type: none">✓ Elektrisch in hoogte verstelbaar✓ Kleur zwart of grijs	<ul style="list-style-type: none">✓ Luxe uitstraling✓ Elektrisch in hoogte verstelbaar

Uw SMART Board uitbreiden

Accessoires

Bekijk alle accessoires op smartboard.nl/shop

VIDEOBARS	WINDOWS SLOT-IN PC
	
<ul style="list-style-type: none">✓ O.a Teams, Zoom en Meet✓ Maak hybride overleg mogelijk	<ul style="list-style-type: none">✓ Intel core i5 of i7 processor✓ Windows 11 PRO

Specificaties



Display	
Screen sizes (diagonal)	65" 75" 86"
Backlight	QLED with Full Array Local Dimming (FALD)
Aspect ratio	16:9
Maximum display resolution	4K UHD (3840 × 2160)
Refresh rate	60 Hz
Lifespan	≥ 50,000 hours
Maximum brightness ¹	≥ 850 cd/m ²
Display response time	≤ 8 ms
Viewing angle	178°
Glass	Full heat-tempered Anti-glare Bonded
Frame color	Brushed graphite
Convenience buttons	Power Volume Input select
Sensors	Ambient light Infrared
Audio	2 integrated 20W speakers with high fidelity audio and integrated 20W subwoofer Integrated linear 8-microphone array array with support for onboard acoustic echo cancellation
Embedded software	
Operating system	Not available
Software	
Included	SMART Meeting Pro® SMART Product Drivers and SMART Ink®
Optional	SMART TeamWorks™

Interactive experience	
Touch technology	HyPr Touch™ with Advanced IR
Touch features	Simultaneous tool differentiation ² Object Awareness™ ³ Silktouch™
Typical touch response time	≤ 3.3 ms
Frame rate	≥ 300 Hz
Accuracy	< 1 mm
Minimum object size	≤ 1.5 mm
Multitouch capabilities	Up to 50 touch points (OS dependent)
Tools included	Pens (×2)
Tool holders	Magnetic Frame-mounted

Interactive experience	
Touch technology	HyPr Touch™ with Advanced IR
Touch features	Simultaneous tool differentiation ² Object Awareness™ ³ Silktouch™
Typical touch response time	≤ 3.3 ms
Frame rate	≥ 300 Hz
Accuracy	< 1 mm
Minimum object size	≤ 1.5 mm
Multitouch capabilities	Up to 50 touch points (OS dependent)
Tools included	Pens (×2)
Tool holders	Magnetic Frame-mounted



Vragen?

Bel 038 - 420 90 90 of mail info@smartboard.nl
www.smartboard.nl

OPS computing

SMART OPS modules⁴	SMART OPS PC modules SMART AM60 appliance
OPS power	90 W
More information	See > smarttech.com/accessories

Inputs	Front	Back
OPS PC accessory slot	–	1
HDMI® 2.1 4K @ 60Hz with HDCP 1.4, HDCP 2.3, ARC, and eARC support ⁵	1	2
Stereo 3.5 mm (variable)	–	1
RS-232 (DB-9 connector)	–	1
RJ45 (LAN In)	–	1
USB Type-C 4K @ 60Hz Display Port 1.2, USB 2.0 (UFP) for touch and digital audio, USB 3.2 Gen 1 (DFP) for peripherals; 100 W power delivery	1	1
USB 2.0 Type-A	–	1
USB 3.2 Gen 1 Type-A	2	2
USB 3.0 Type-B	1	1

Outputs	Front	Back
HDMI 2.1 4K @ 60Hz with HDCP 1.4, HDCP 2.3, ARC, and eARC support ⁵	–	1
Stereo 3.5 mm (variable)	–	1
S/PDIF optical (fixed)	–	1
RJ45 (LAN Out)	–	1

Included cables and accessories	Qty
Country-specific power cable	1
16' 5" (5 m) USB 2.0 A to B cable	1
6' (1.8 m) USB 3.2 Gen 1 Type-C cable, 5A	1
Pens	2
Remote control	1
AAA batteries	2
Illustrated installation instructions	1
Important information document	1

Connectivity

Wired	RJ45 (x2) 1000BASE-T
--------------	----------------------

Cable requirements

See > [SMART cables and connectors guide](https://docs.smarttech.com/kb/171926)
(docs.smarttech.com/kb/171926)

Storage and operating requirements

Power requirements	100V to 240V AC, 50 Hz to 60 Hz
Operating temperature	32–104°F (0–40°C)
Storage temperature	14–140°F (–10–60°C)
Humidity	20–80% relative humidity, non-condensing

Power consumption⁶

Typical	65": 90 W 75": 107 W 86": 128 W
Standby	<0.5 W

Certification and compliance⁷

Regulatory models	IDT65-1 IDT75-1 IDT86-1
US / Canada	cULus FCC ISED TSCA CONEG Packaging Proposition 65
EU / EEA / EFTA / UK	CE UKCA LVD CB EMC REACH RoHS Battery WEEE Packaging POP Ecodesign
Australia / New Zealand	RCM
Performance standards	DOLBY VISION® ENERGY STAR® HDMI HDCP HDR10 HLG

Purchasing information⁸

Order numbers

T065-P	SMART Board® T065 Pro interactive display, QLED, no embedded OS
T075-P	SMART Board T075 Pro interactive display, QLED, no embedded OS
T086-P	SMART Board T086 Pro interactive display, QLED, no embedded OS

Optional accessories

See > smarttech.com/accessories

SMART Warranty

Terms and conditions and warranty upgrade options vary by region. Visit smarttech.com/warranty or contact your reseller for information.



Vragen?

Bel 038 - 420 90 90 of mail info@smartboard.nl
www.smartboard.nl

Installation, dimensions, and weights

Notes

- All dimensions $\pm 1/8"$ (0.3 cm). All weights ± 2 lb. (0.9 kg).
- Product ships upright.

65" models

Dimensions

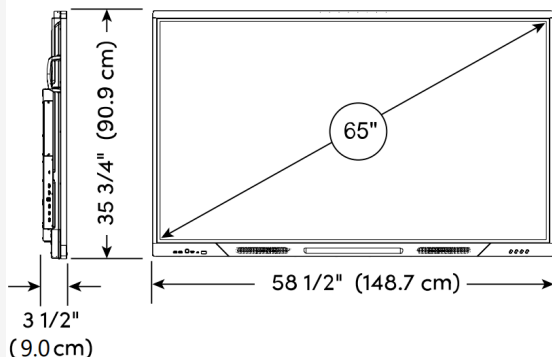

Weight

80 lb. (36 kg)

Shipping dimensions (excluding pallet)

62 1/4" x 39 3/8" x 5 3/8"
(158 cm x 99.9 cm x 13.8 cm)

Shipping weight

100 lb. (45 kg)

VESA mount

M8 | 600 x 400 mm

Handles

2

75" models

Dimensions

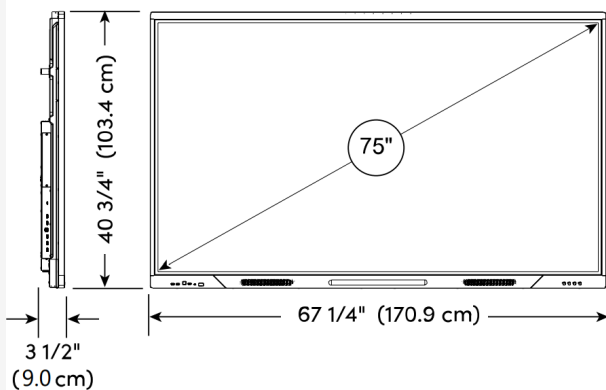

104 lb. (47 kg)

Shipping dimensions (excluding pallet)

70 7/8" x 44 1/4" x 5 3/8"
(180.1 cm x 112.2 cm x 13.8 cm)

Shipping weight

127 lb. (58 kg)

VESA mount

M8 | 800 x 400 mm

Handles

2

86" models

Dimensions

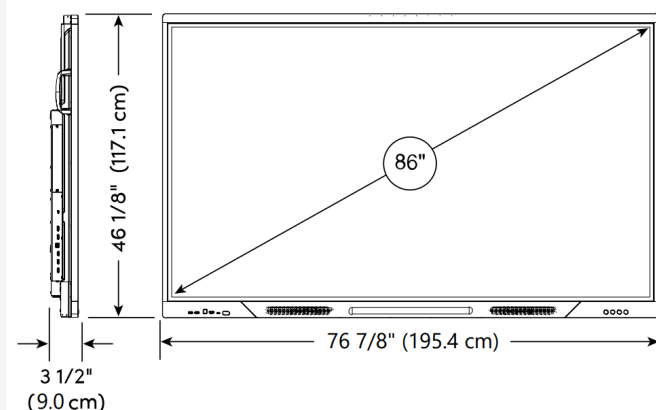

139 lb. (63 kg)

Shipping dimensions (excluding pallet)

80 1/2" x 49 5/8" x 5 3/8"
(204.5 cm x 126.1 cm x 13.8 cm)

Shipping weight

167 lb. (76 kg)

VESA mount

M8 | 800 x 600 mm

Handles

2